

HYUNDAI
POWER PRODUCTS

PETROL HIGH WHEEL BRUSHCUTTER

HDBTR5660

ORIGINAL INSTRUCTIONS



WARNING: Read thoroughly the instruction manual before use.

CONTENTS

1. INTENDED USE	3
2. IMPORTANT SAFE OPERATION PRACTICES	3
3. ASSEMBLY & SET-UP	9
4. CONTROLS & FEATURES	12
5. OPERATION	13
6. MAINTENANCE & ADJUSTMENTS	15
7. TROUBLESHOOTING	17
8. TECHNICAL DATA	18
9. DECLARATION OF CONFORMITY	19
10. WARRANTY	20
11. PRODUCT FAILURE	21
12. WARRANTY EXCLUSIONS	22

1. INTENDED USE

This device is only for trimming grass, vegetation, undergrowth and weeds in the domestic area. The device is designed for domestic use. It is not intended for continuous professional use. Any other use that is not expressly permitted in this manual may result in damage to the device and constitute a serious danger to the user.

This device is designed for use by adults. Children and those unfamiliar with this manual should not use this device. The user is responsible for accidents or damage caused to people or their property. The manufacturer is not liable for damage caused by improper use or improper handling.

2. IMPORTANT SAFE OPERATION PRACTICES

**IMPORTANT
READ CAREFULLY BEFORE USE
KEEP FOR FUTURE REFERENCE**

Training

Read the instructions carefully. Be familiar with the controls and the proper use of the trimmer.

Preparation

- a) Warning: never allow people unfamiliar with these instructions to use the trimmer; never allow children to use the trimmer.
- b) Local regulations may restrict the age of the operator.
- c) Never trim while people, especially children, or pets are nearby.
- d) Wear safety glasses or goggles at all times when operating the trimmer.
- e) Wear ear protection.
- f) While operating the trimmer, always wear substantial footwear and long trousers. Do not operate the trimmer when barefoot or wearing open sandals.
- g) Thoroughly inspect the area where the trimmer is to be used and remove all objects which may be thrown by the trimmer.
- h) WARNING: Fuel is highly flammable:
 - Store fuel in containers specifically designed for this purpose.
 - Refuel outdoors only and do not smoke while refueling.
 - Add fuel before starting the engine. Never remove the cap of the fuel tank or add fuel while the engine is running or when the engine is hot.
 - If fuel is spilled, do not attempt to start the engine but move the trimmer away from the area of spillage and avoid creating any source of ignition until fuel vapors have dissipated.
 - Replace all fuel tanks and container caps securely.
- i) Replace faulty silencers.
- j) Before using, always visually inspect to see that the cutting elements and cutting means are not worn or damaged. Replace worn or damaged cutting elements in sets to preserve balance.

Operation

- a) Do not operate the engine in a confined space where dangerous carbon monoxide fumes can collect.
- b) Trim only in daylight or in good artificial light.
- c) Avoid operating the trimmer in wet grass, or take additional precautions to avoid slipping.
- d) Always be sure of your footing on slopes.
- e) Walk, never run.
- f) Trim across the face of slopes, never up and down.
- g) Exercise extreme caution when changing direction on slopes.
- h) Do not trim on steep slopes.
- i) Use extreme caution when reversing or pulling the trimmer towards you.
- j) Stop the cutting means if the trimmer has to be tilted for transportation when crossing surfaces other than grass, and when transporting the trimmer to and from the working area.
- k) Never operate the trimmer with defective guards, or without safety devices, in place.
- l) Do not change the engine governor settings or over-speed the engine.
- m) Disengage all cutting means and drive clutches before starting the engine.
- n) Start the engine carefully according to instructions and with feet well away from the cutting elements.

- o) Do not tilt the trimmer when starting the engine, except if the trimmer has to be tilted for starting. In this case, do not tilt it more than absolutely necessary and lift only the part which is away from the operator.
- p) Do not put hands or feet near or under rotating parts.
- q) Never pick up or carry the trimmer while the engine is running.



WARNING: Stop the engine and disconnect the spark plug wire and for battery start trimmers remove the ignition key:

- Before clearing blockages.
 - Before checking, cleaning or working on the trimmer.
 - After striking a foreign object and inspect the trimmer. Do not restart or operate the trimmer until any necessary repairs have been done.
 - If the trimmer starts to vibrate abnormally or the operating noise increases and check immediately. Do not restart or operate the trimmer until any necessary repairs have been done.
 - Whenever you leave the trimmer.
 - Before refueling.
- r) reduce the throttle setting during engine shut down and, if the engine is provided with a shut-off valve, turn the fuel off at the conclusion of trimming.

Maintenance and storage

- a) Keep all nuts, bolts and screws tight to be sure the trimmer is in safe working condition.
- b) Never store the trimmer with petrol in the tank inside a building where fumes may reach an open flame or spark.
- c) Allow the engine to cool before storing in an enclosed space.
- d) To reduce the fire hazard, keep the engine, silencer, battery compartment and petrol storage area free of grass, leaves, or excessive grease;
- e) Examine the trimmer regularly and replace worn or damaged parts for safety. Never replace the cutting means with metal parts and only use cutting means (cutting heads and cutting elements) which are suitable for use at the operating speed of the trimmer.
- f) If the fuel tank has to be drained, this should be done outdoors. The drained fuel should be stored in a container specifically designed for fuel storage or it should be disposed of carefully.

GENERAL OPERATION

1. Read this operator's manual carefully in its entirety before attempting to assemble this machine. Read, understand, and follow all instructions on the machine and in the manual(s) before operation. Keep this manual in a safe place for future and regular reference and for ordering replacement parts.
2. Be completely familiar with the controls and the proper use of this machine before operating it.
3. Exercise extreme caution at all times. This machine has been designed to perform one job: to cut vegetation and grass. Do not use it for any other purpose.
4. Never allow children under 14 years of age to operate this machine. Children 14 and over should read and understand the instructions and safe operation practices in this manual and on the machine and should be trained and supervised by an adult.
5. Only responsible individuals who are familiar with these rules of safe operation should be allowed to use this machine.
6. Thoroughly inspect the area where the equipment is to be used. Remove all stones, sticks, wire, bones, toys and other foreign objects, which could be tripped over or picked up and thrown by the string trimmer. Thrown objects can cause serious personal injury.
7. Plan your trimming pattern to avoid discharge of material toward roads, sidewalks, bystanders and the like. Also, avoid discharging material against a wall or obstruction, which may cause discharged material to ricochet back toward the operator.
8. To help avoid trimmer line contact or a thrown object injury, stay in operator zone behind handles and keep children, bystanders, helpers and pets at least 75 feet from string trimmer while it is in operation. Stop machine if anyone enters area.
9. Always wear safety glasses or safety goggles during operation and while performing an adjustment or repair to protect your eyes. Thrown objects which ricochet can cause serious injury to the eyes.
10. Wear sturdy, rough-soled work shoes and close-fitting slacks and shirts. Shirts and pants that cover the arms and legs and steel-toed shoes are recommended. Never

- operate this machine in bare feet, sandals, slippery or light- weight (e.g. canvas) shoes.
11. Do not put hands or feet near or under rotating parts. Keep clear of discharge area at all times as the rotating spindle and trimmer lines can cause injury.
 12. Never operate the string trimmer without proper shields, guards, control lever or other safety protective devices in place and working.
 13. Never operate the string trimmer with damaged safety devices. Failure to do so, can result in personal injury.
 14. Many injuries occur as a result of the string trimmer being pulled over the foot during a fall caused by slipping or tripping. Do not hold on to the string trimmer if you are falling; release the handle immediately.
 15. Never pull the string trimmer back toward you while you are walking. If you must back the string trimmer away from a wall or obstruction first look down and behind to avoid tripping and then follow these steps:
 - a. Step back from string trimmer to fully extend your arms.
 - b. Be sure you are well balanced with sure footing.
 - c. Pull the string trimmer back slowly, no more than halfway toward you.
 - d. Repeat these steps as needed.
 15. Do not operate the string trimmer while under the influence of alcohol or drugs.
 16. Do not engage the self-propelled mechanism on machines so equipped while starting engine.
 17. The control lever is a safety device. Never attempt to bypass its operation. Doing so makes the safety device inoperative and may result in personal injury through contact with the rotating trimmer line. The control lever must operate easily in both directions and automatically return to the disengaged position when released.
 18. Never operate the string trimmer in wet grass. Always be sure of your footing. A slip and fall can cause serious personal injury. If you feel you are losing your footing, release the control lever immediately and the spindle will stop rotating within three seconds.
 19. Operate only in daylight or good artificial light. Walk, never run.
 20. Stop the spindle when crossing gravel drives, walks or roads.
 21. If the equipment should start to vibrate abnormally, stop the engine and check immediately for the cause. Vibration is generally a warning of trouble.
 22. Shut the engine off and wait until the spindle comes to a complete stop before cleaning the discharge area. The spindle continues to rotate for a few seconds after the control lever is released. Never place any part of the body in the trimmer line area until you are sure the spindle has stopped rotating.
 23. Never operate string trimmer without proper trail shield, discharge cover, control lever or other safety protective devices in place and working. Never operate string trimmer with damaged safety devices. Failure to do so can result in personal injury.
 24. Muffler and engine become hot and can cause a burn. Do not touch.
 25. Only use parts and accessories made for this machine by the manufacturer. Failure to do so can result in personal injury.
 26. When starting engine, pull cord slowly until resistance is felt, then pull rapidly. Rapid retraction of starter cord (kickback) will pull hand and arm toward engine faster than you can let go. Broken bones, fractures, bruises or sprains could result.
 27. If situations occur which are not covered in this manual, use care and good judgement. Contact Customer Support for assistance or the nearest service dealer.

SLOPE OPERATION

Slopes are a major factor related to slip and fall accidents, which can result in severe injury. Operation on slopes requires extra caution. If you feel uneasy on a slope, do not trim on it. For your safety, use the slope gauge included as part of this manual to measure slopes before operating this machine on a sloped or hilly area. If the slope is greater than 15 degrees, do not trim on it.

Do

1. Trim across the face of slopes; never up and down. Exercise extreme caution when changing direction on slopes.
2. Watch for holes, ruts, rocks, hidden objects, or bumps which can cause you to slip or trip. Tall grass can hide obstacles.
3. Always be sure of your footing. A slip and fall can cause serious personal injury. If you feel you are losing your balance, release the control lever immediately and the spindle will stop rotating within three (3) seconds.

Do Not

1. Do not trim near drop-offs, ditches or embankments, you could lose your footing or balance.
2. Do not trim slopes greater than 15 degrees as shown on the slope gauge.
3. Do not trim on wet grass. Unstable footing could cause slipping.

Children

Tragic accidents can occur if the operator is not alert to the presence of children. Children are often attracted to the string trimmer and the trimming activity. They do not understand the dangers. Never assume that children will remain where you last saw them.

1. Keep children out of the trimming area and under watchful care of a responsible adult other than the operator.
2. Be alert and turn string trimmer off if a child enters the area.
3. Before and while moving backwards, look behind and down for small children.
4. Use extreme care when approaching blind corners, doorways, shrubs, trees, or other objects that may obscure your vision of a child who may run into the string trimmer.
5. Keep children away from hot or running engines. They can suffer burns from a hot muffler.
6. Never allow children under 14 years of age to operate this machine. Children 14 and over should read and understand the instructions and safe operation practices in this manual and on the machine and be trained and supervised by an adult.

SERVICE

Safe Handling Of Gasoline

1. To avoid personal injury or property damage use extreme care in handling gasoline. Gasoline is extremely flammable and the vapors are explosive. Serious personal injury can occur when gasoline is spilled on yourself or your clothes, which can ignite. Wash your skin and change clothes immediately.
2. Use only an approved gasoline container.
3. Never fill containers inside a vehicle or on a truck or trailer bed with a plastic liner. Always place containers on the ground away from your vehicle before filling.
4. Remove gas-powered equipment from the truck or trailer and refuel it on the ground. If this is not possible, then refuel such equipment on a trailer with a portable container, rather than from a gasoline dispenser nozzle.
5. Keep the nozzle in contact with the rim of the fuel tank or container opening at all times until fueling is complete. Do not use a nozzle lock-open device.
6. Extinguish all cigarettes, cigars, pipes and other sources of ignition.
7. Never fuel machine indoors because flammable vapors will accumulate in the area.
8. Never remove gas cap or add fuel while engine is hot or running. Allow engine to cool at least two minutes before refueling.
9. Never over fill fuel tank. Fill tank to no more than 1 inch below bottom of filler neck to provide for fuel expansion.
10. Replace gasoline cap and tighten securely.
11. If gasoline is spilled, wipe it off the engine and equipment. Move machine to another area. Wait 5

minutes before starting engine.

12. Never store the machine or fuel container near an open flame, spark or pilot light as on a water heater, space heater, furnace, clothes dryer or other gas appliances.
13. To reduce fire hazard, keep machine free of grass, leaves, or other debris build-up. Clean up oil or fuel spillage and remove any fuel soaked debris.
14. Allow machine to cool at least 5 minutes before storing.

General Service

1. Never run an engine indoors or in a poorly ventilated area. Engine exhaust contains carbon monoxide, an odorless and deadly gas.
2. Before cleaning, repairing, or inspecting, make certain the spindle and all moving parts have stopped. Disconnect the spark plug wire and ground against the engine to prevent unintended starting.
3. Check the spindle and engine mounting bolts at frequent intervals for proper tightness. Also, visually inspect spindle for damage. Replace with the original equipment manufacturer's (O.E.M.) parts only, listed in this manual. "Use of parts which do not meet the original equipment specifications may lead to improper performance and compromise safety!"
4. Keep all nuts, bolts, and screws tight to be sure the equipment is in safe working condition.
5. Never tamper with safety devices. Check their proper operation regularly.
6. After striking a foreign object, stop the engine, disconnect the spark plug wire and ground against the engine. Thoroughly inspect the string trimmer for any damage. Repair the damage before starting and operating the string trimmer.
7. Trimmer components, guards and shields are subject to wear and damage which could expose moving parts or allow objects to be thrown. For safety protection, frequently check components and replace immediately with original equipment manufacturer's (O.E.M.) parts only, listed in this manual. "Use of parts which do not meet the original equipment specifications may lead to improper performance and compromise safety!"
8. Do not change the engine's governor setting or over-speed the engine. The governor controls the maximum safe operating speed of the engine.
9. Check fuel line, tank, cap, and fittings frequently for cracks or leaks. Replace if necessary.
10. Do not crank engine with spark plug removed.
11. Maintain or replace safety and instruction labels, as necessary.
12. Observe proper disposal laws and regulations. Improper disposal of fluids and materials can harm the environment.

Do not modify engine

To avoid serious injury or death, do not modify engine in any way. Tampering with the governor setting can lead to a runaway engine and cause it to operate at unsafe speeds. Never tamper with factory setting of engine governor.







Spark Arrestor



WARNING: This machine is equipped with an internal combustion engine and should not be used on or near any unimproved forest-covered, brush covered or grass-covered land unless the engine's exhaust system is equipped with a spark arrestor meeting applicable local or state laws (if any).

SAFETY SYMBOLS

This page depicts and describes safety symbols that may appear on this product. Read, understand, and follow all instructions on the machine before attempting to assemble and operate.

Symbol	Description
	READ THE OPERATOR MANUAL Read, understand, and follow all instructions in the manual(s) before attempting to assemble and operate
	EYE AND EAR PROTECTION Always wear safety glasses and earmuffs or safety goggles when operating this machine.
	DANGER — BYSTANDERS Do not trim when children or others are around.
	DANGER — HAND/ FOOT CUT Keep hands and feet away from rotating parts.
	DANGER — THROWN DEBRIS Remove objects that can be thrown by the machine in any direction. Wear safety glasses.
	DANGER — SLOPES Use extra caution on slopes. Do not trim on slopes greater than 15°.
	WARNING—GASOLINE IS FLAMMABLE Allow the engine to cool at least two minutes before refueling.
	WARNING— CARBON MONOXIDE Never run an engine indoors or in a poorly ventilated area. Engine exhaust contains carbon monoxide, an odorless and deadly gas.
	WARNING— HOT SURFACE Engine parts, especially the muffler, become extremely hot during operation. Allow engine and muffler to cool before touching.
	WARNING SYMBOLS
	DO NOT USE SAW BLADES
	KEEP BYSTANDERS AWAY AT LEAST 15M

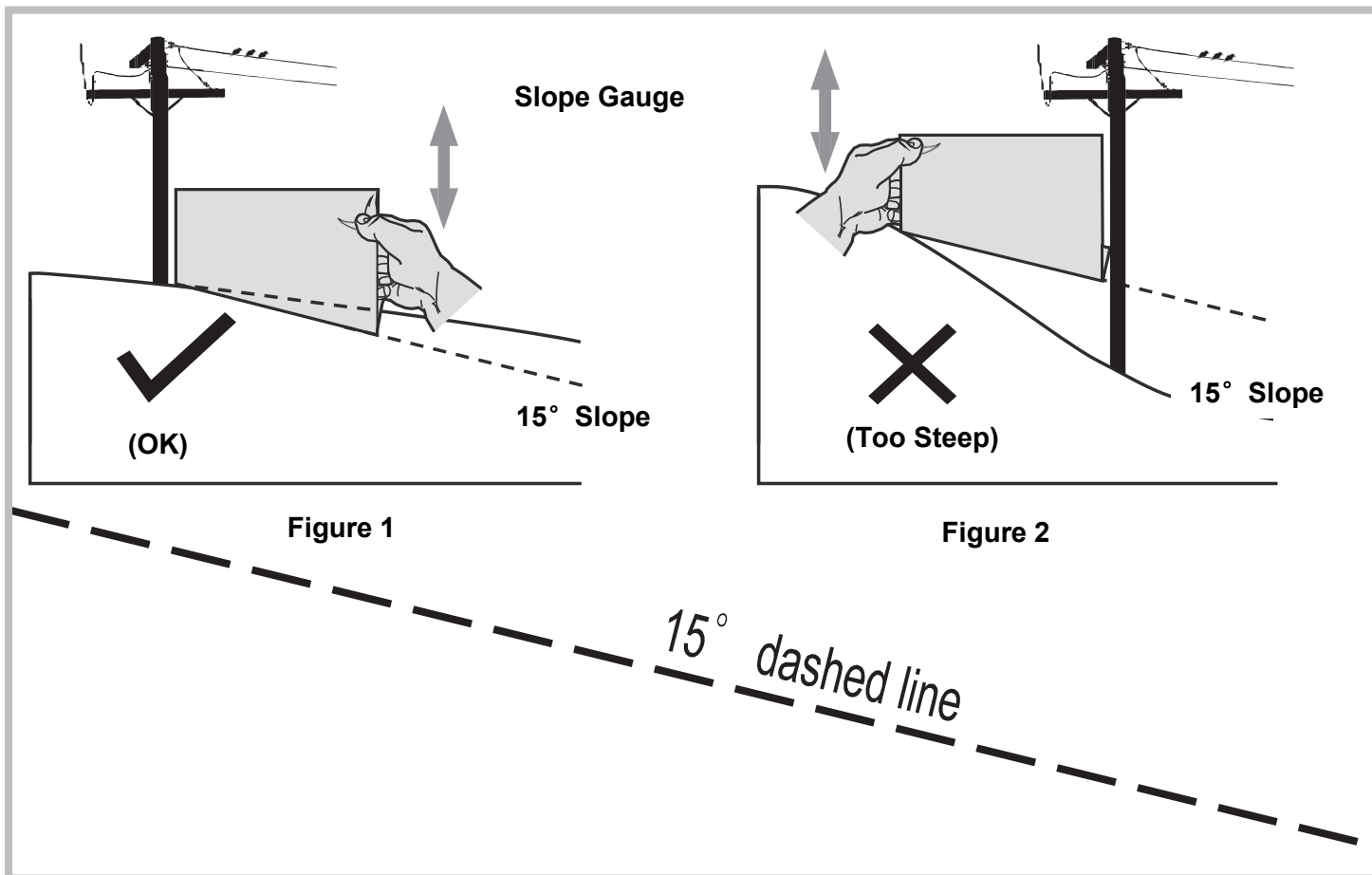

USE THIS SLOPE GAUGE TO DETERMINE IF A SLOPE IS TOO STEEP FOR SAFE OPERATION!

To check the slope, proceed as follows:

1. Remove this page and fold along the dashed line.
2. Locate a vertical object on or behind the slope (e.g. a pole, building, fence, tree, etc.)
3. Align either side of the slope gauge with the object (See Figure 1 and Figure 2).
4. Adjust gauge up or down until the left corner touches the slope (See Figure 1 and Figure 2).
5. If there is a gap below the gauge, the slope is too steep for safe operation (See Figure 2 above).



WARNING! Slopes are a major factor related to tip-over and roll-over accidents which can result in severe injury or death. Do not operate machine on slopes in excess of 15 degrees. All slopes require extra caution.

Always mow across the face of slopes, never up and down slopes.

3. ASSEMBLY & SET-UP

CONTENTS OF CARTON

- One String Trimmer
- One Pack of Trimmer Line
- Operator's Manual

ASSEMBLY

NOTE: This string trimmer is shipped without gasoline or oil in the engine. Fill up the gasoline and oil as instructed in the accompanying engine manual BEFORE operating your machine.

Middle Handle

1. Remove the triangle knob and carriage bolt from the left lower handle and the right lower handle.
2. Pivot the middle handle into the operating position and fasten the middle handle. See Figure 3-1

Upper Handle

1. Remove the knob and carriage bolt from the left upper handle and the right upper triangle handle.
2. Find the upper handle and move the upper handle into one of two positions by pivoting and fasten the middle handle. See Figure 3-2

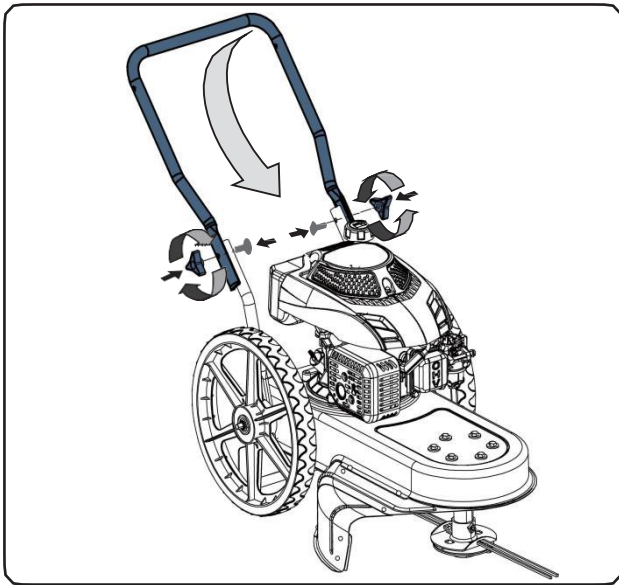

Figure 3-1

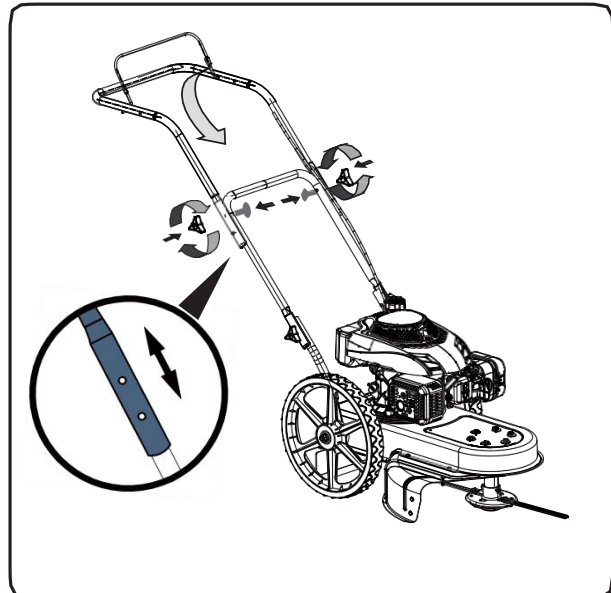

Figure 3-2

Starter Rope

1. Disconnected the spark plug boot from the spark plug.
2. Pivot the control handle against the upper handle and pull the rope out of the engine.
3. Put the starter rope into the hook. See Figure 3-3

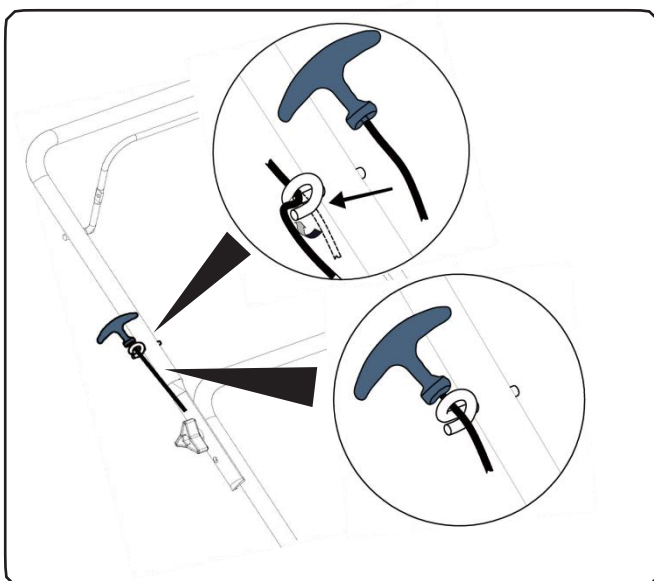
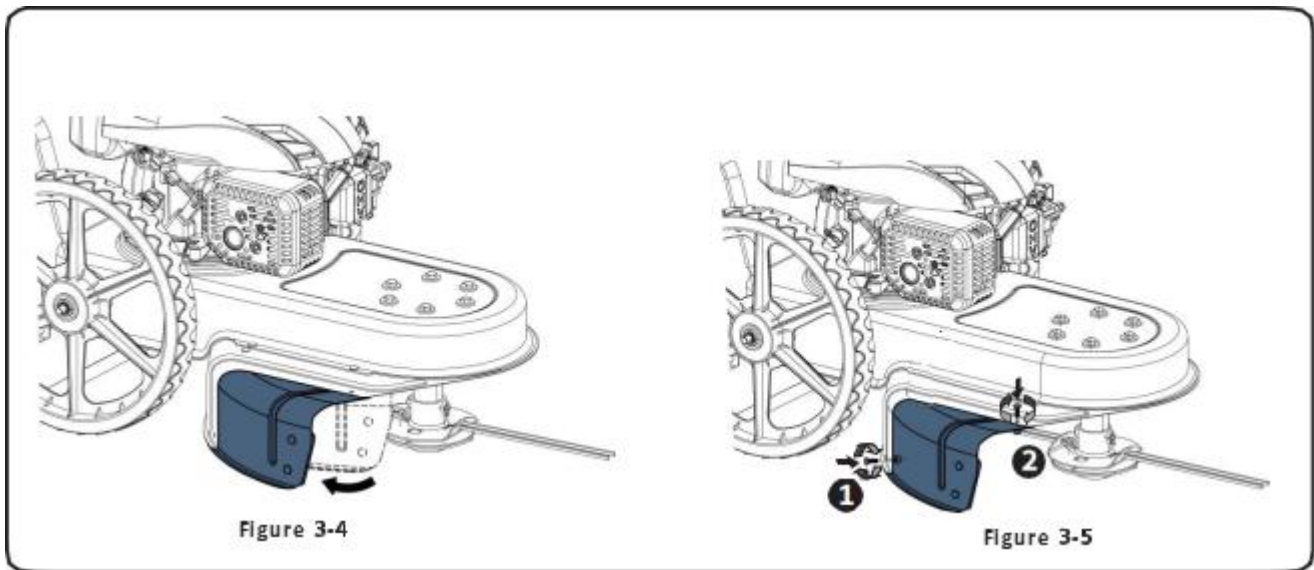

Figure 3-3

Assembly Trimmer Shield

1. Pull the trimmer shield out into position by pivoting the hole. See Figure 3-4.
2. Insert the bolt into the hole with screw the nut and fasten it by tool. See Figure 3-5.



SET-UP

Gas and Oil Fill-Up

1. Add oil provided before starting unit for the first time out of the box.



WARNING: Use extreme care when handling gasoline. Gasoline is extremely flammable and the vapors are explosive. Never fuel the machine indoors or while the engine is hot or running. Extinguish cigarettes, cigars, pipes and any other sources of ignition. See Figure 3-6.



Figure 3-6

4. CONTROLS AND FEATURES

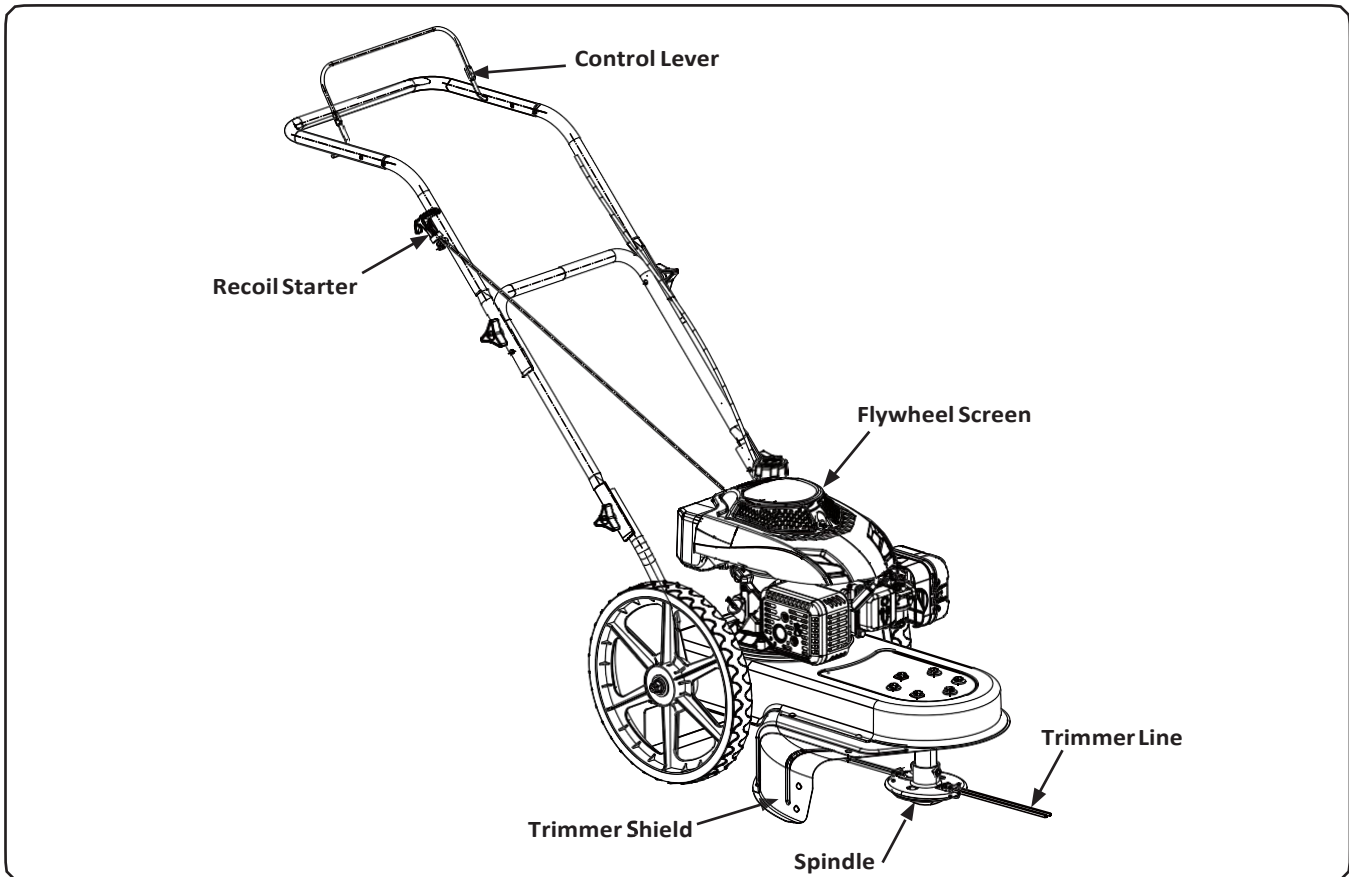

Figure 4-6

Recoil Starter

The recoil starter is attached to the right side of the upper handle. Stand behind the unit and pull the recoil starter rope to start the unit.

Trimmer shield

The trimmer shield is connected to the trimmer base and it is used to prevent debris from being thrown.

Control Lever

The control lever must be depressed to start the engine and rotation of trimmer spindle assembly. Releasing the control lever stops the engine and trimmer spindle assembly.



WARNING: This control lever is a safety device. Never attempt to bypass its operations.

Spindle

The spindle rotates the trimmer line.

Trimmer Line

The trimmer line is attached to the spindle assembly and it is used to trim grass, vegetation, undergrowth and weeds.

Flywheel Screen

Keep the flywheel screen free of grass clippings and debris at all times.

5. OPERATION

Adjusting the Spindle Height

The spindle height can be adjusted for various applications. To do so, proceed as follows:

1. Loosen the bolt found on each side of the spindle shaft. **Note:** The bolts are designed so that they cannot be removed from the spindle shaft.
2. Slide the spindle upward or downward to the desired position before retightening the bolts. See Figure 5-1.

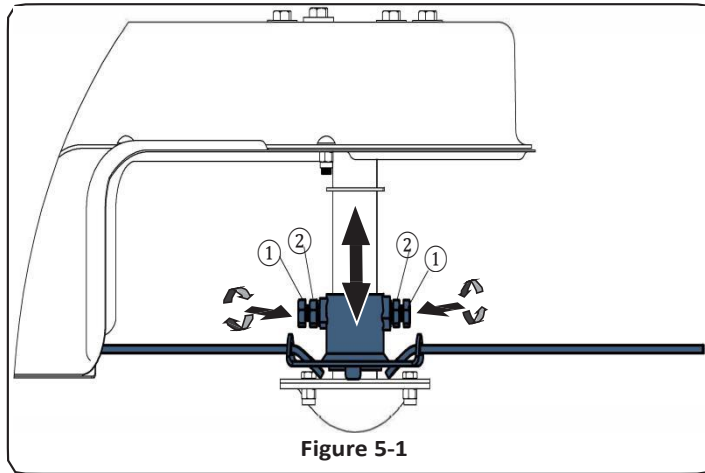

Starting and Stopping

1. Press the priming pump one or two times and depress control lever. See Figure 5-2 ①. and pull the starter rope to start the engine. See Figure 5-2 ②.
2. Releasing the control lever stops the engine.

Using Your String Trimmer

Be sure trimming area is clear of stones, sticks, wire, or other objects which could damage the string trimmer or engine. Such objects could be accidentally thrown by the trimmer in any direction and cause serious personal injury to the operator and others.

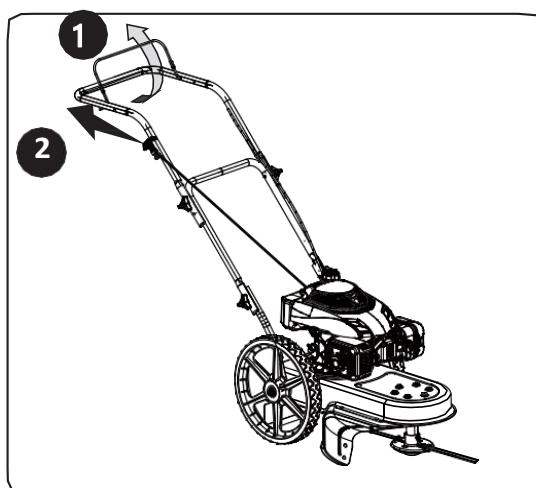

Figure 5-2



WARNING: The operation of any string trimmer can result in foreign objects being thrown into the eyes, which can damage your eyes severely. Always wear safety glasses while operating the string trimmer, or while performing any adjustments or repairs on it.

- The string trimmer is designed with the spindle off set to the left side, allowing the operator to trim along a fence, landscaping, or a house to his or her's right side without having to make any adjustments to the machine.
- Operate the string trimmer at a slower walking speed when trimming tall, thick weeds or grass.
- Clean the underside of the trimmer after each use to remove any debris build up.



WARNING: Shut the engine off and wait until the trimmer head comes to a complete stop before cleaning the discharge area. The trimmer head continues to rotate for a few seconds after the trimmer head control is released.

- Do not trim on excessively steep slopes. If a slope is difficult to stand on, do not trim. Do not trim on slopes when the ground is slippery or wet. Trim across the face of a slope, not up and down.

CAUTION: While operating the string trimmer, do not allow the spindle to contact a concrete, asphalt, or gravel surface. Doing so will result in premature wear.

Changing the Trimmer Line

To ease in removing worn trimmer line, change the trimmer line before it becomes too short (i.e. approximately half its original length).

1. Remove the worn trimmer line from the spindle.
2. Fold the replacement trimmer line in half and insert both ends through the loop near the edge of the spindle.
3. Pull the ends of the trimmer line through the loop until the line is securely beneath the metal tab.
4. Cross the line ends and pull each tightly to secure the trimmer line in place. See Figure 5-3

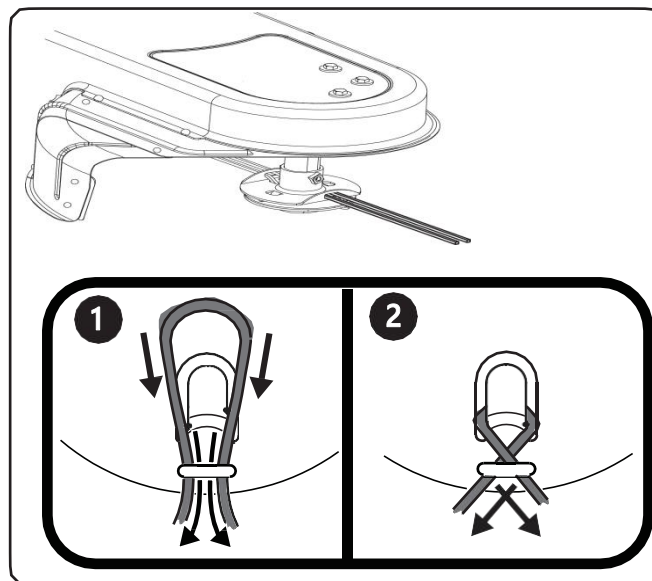

Figure 5-3

6. MAINTENANCE & ADJUSTMENTS

MAINTENANCE

General Recommendations

- Always observe safety rules when performing any maintenance.
- The warranty on this string trimmer does not cover items that have been subjected to operator abuse or negligence. To receive full value from warranty, operator must maintain the string trimmer as instructed here.
- Changing of engine-governed speed will void engine warranty.
- All adjustments should be checked at least once each season.
- Periodically check all fasteners and make sure these are tight.



WARNING: Always stop engine, disconnect spark plug, before performing any type of maintenance on your machine.

Lubrication

1. Lubricate pivot points on the control lever at least once a season with light oil. This control must operate freely in both directions. See Figure 6-1.



Figure 6-1

2. Lubricate the wheels at least once a season with light oil (or motor oil). If wheels are removed for any reason, lubricate surface of the axle bolt and inner surface of the wheel with light oil. See Figure 6-1.
3. Follow the accompanying engine manual for lubrication schedule and instruction for engine lubrication.

Deck Care

Clean underside of the machine after each use to prevent build-up of grass clippings or other debris. Follow steps below:

1. Disconnect spark plug wire. Drain gasoline from string trimmer or place a piece of plastic under the gas cap.
2. Tip trimmer so that it rests on its side. Keep the side with the air cleaner facing up. Hold trimmer firmly.



WARNING: Never tip the trimmer more than 90° in any direction and do not leave the trimmer tipped for any length of time. Oil can drain into the upper part of the engine causing a starting problem.

3. Scrape and clean the underside of the machine with a suitable tool. Do not spray with water.
IMPORTANT: Do not use a pressure washer or garden hose to clean the machine. These may cause damage to the engine. The use of water will result in shortened life and reduce serviceability.
4. Put the trimmer back on its wheels on the ground. If you had put plastic under the gas cap earlier, make sure to remove it now.

Engine Care

A list of key engine maintenance jobs required for good performance by the trimmer is given below. Follow the accompanying engine manual for a detailed list and instructions.

- Maintain oil level as instructed in engine manual.
- Service air cleaner every 25 hours under normal conditions. Clean every few hours under extremely dusty conditions. Poor engine performance and flooding usually indicates that the air cleaner should be serviced. To service the air cleaner, refer to the engine manual.
- Clean spark plug and reset the gap once a season. Spark plug replacement is recommended at the start of each mowing season. Check engine manual for correct plug type and gap specifications.
- Clean engine regularly with a cloth or brush. Keep the top of the engine clean to permit proper air circulation. Remove all grass, dirt and debris from muffler area.
- Engines stored between 30 and 90 days need to be treated with a gasoline stabilizer to prevent deterioration and gum from forming in fuel system or on essential carburetor parts.

Off-Season Storage

Take the following steps to prepare your trimmer for storage. Refer to engine manual for specific engine storage instructions:

- Clean and lubricate trimmer.
- Store trimmer in a dry, clean area. Do not store next to corrosive materials, such as fertilizer.
- Using a light oil or silicone, coat the equipment, especially cables and all moving parts of your string trimmer.

7. TROUBLESHOOTING

Problem	Cause	Remedy
Engine Fails to start	<ol style="list-style-type: none"> Control lever disengaged. Spark plug boot disconnected. Fuel tank empty or stale fuel. Engine not primed (if equipped with primer). Faulty spark plug. Blocked fuel line. Engine flooded. Fuel valve (if equipped) closed. Engine not choked (if equipped with choke). 	<ol style="list-style-type: none"> Engage control lever. Connect wire to spark boot. Fill tank with clean, fresh gasoline. Prime engine as instructed in the Operation section. Clean, adjust gap, or replace. Clean fuel line. Wait a few minutes to restart, but do not prime. Open fuel valve. See engine manual. Choke engine. See engine manual.
Engine runs erratic	<ol style="list-style-type: none"> Spark plug boot loose. Blocked fuel line or stale fuel. Vent in gas cap plugged. Water or dirt in fuel system. Dirty air cleaner. Unit running with CHOKE (if equipped) applied. 	<ol style="list-style-type: none"> Connect and tighten spark plug boot. Clean fuel line; fill tank with clean, fresh gasoline. Clear vent. Drain fuel tank. Refill with fresh fuel. Refer to engine manual. Push CHOKE knob in.
Engine overheats	<ol style="list-style-type: none"> Engine oil level low. Air flow restricted. 	<ol style="list-style-type: none"> Fill crankcase with proper oil. Clean area around and on top of engine.
Occasional skips (hesitates) at high speed	<ol style="list-style-type: none"> Spark plug gap too close. 	<ol style="list-style-type: none"> Adjust gap to .030".
Idles poorly	<ol style="list-style-type: none"> Spark plug fouled, faulty, or gap too wide. Dirty air cleaner. 	<ol style="list-style-type: none"> Reset gap to .030" or replace spark plug. Refer to engine manual.
Excessive Vibration	<ol style="list-style-type: none"> Spindle wing nuts loose. Spindle damaged. 	<ol style="list-style-type: none"> Tighten wing nuts. See an authorized service dealer.
Poor Trimming Performance	<ol style="list-style-type: none"> Trimmer line too short or worn. Worn or damaged spindle belt. 	<ol style="list-style-type: none"> Replace trimmer line. Replace spindle belt.

8. TECHNICAL DATA

Model	HDBTR5660
Power	3 kW
Cylinder capacity	161 cm ³
Engine speed	3000/min
Cutting width	560mm
Wheel diameter	355mm
Guaranteed Sound Power Level	105 dB(A)
Sound power level	102 dB (A); K=3 dB(A)
Sound pressure level	88 dB (A) K= 3 dB(A)
Vibration	6.812 m/s ² K= 1,5 m/s ²

Information

- The declared vibration total value has been measured in accordance with a standard test method and may be used for comparing one tool with another;
- The declared vibration total value may also be used in a preliminary assessment of exposure.

Warning

- that the vibration emission during actual use of the power tool can differ from the declared total value depending on the ways in which the tool is used;
- And of the need to identify safety measures to protect the operator that are based on an estimation of exposure in the actual conditions of use (taking account of all parts of the operating cycle such as the times when the tool is switched off and when it is running idle in addition to the trigger time).

Wear hearing protection.

9. DECLARATION OF CONFORMITY



BUILDER SAS

ZI, 32 rue Aristide Bergès – 31270 Cugnaux - France

Declares that the machinery designated below:

PETROL HIGH WHEEL BRUSHCUTTER

Ref.:HDBTR5660

Serial number: 20220507751-20220508462

Complies with the provisions of the Directive “machinery” 2006/42/CE and national laws transposing it:

Also complies with the following European directives:

EMC Directive 2014/30/EU

ROHS Directive (EU)2015/863 amending 2011/65/EU

Emission directive (EU) 2016/1628 & 2017/656/EU

Directive on environmental noise emissions from equipment intended for use outside buildings
2000/14/EC

Guaranteed Sound Power Level: 105 dB(A)

Also complies with European standards, with national standards and the following technical provisions:

EN 14910: 2007/A1: 2009

EN ISO14982: 2009

Cugnaux, 16/03/2022

Philippe MARIE / PDG

10. WARRANTY

HYUNDAI

WARRANTY

The manufacturer guarantees the product against defects in material and workmanship for a period of 2 years from the date of the original purchase. The warranty only applies if the product is for household use. The warranty does not cover breakdowns due to normal wear and tear.

The manufacturer agrees to replace parts identified as defective by the designated distributor. The manufacturer does not accept responsibility for the replacement of the machine, in whole or in part, and/or ensuing damage.

The warranty does not cover breakdowns due to:

- insufficient maintenance.
- abnormal assembly, adjustment or operations of the product.
- parts subject to normal wear and tear.

The warranty does not extend to:

- shipping and packaging costs.
- using the tool for a purpose other than that for which it was designed.
- the use and maintenance of the machine done in a manner not described in the user manual.

Due to our policy of continuous product improvement, we reserve the right to alter or change specifications without notice. Consequently, the product may be different from the information contained therein, but a modification will be undertaken without notice if it is recognized as an improvement of the preceding characteristic.

READ THE MANUAL CAREFULLY BEFORE USING THE MACHINE.

When ordering spare parts, please indicate the part number or code, you can find this in the spare parts list in this manual. Keep the purchase receipt; without it, the warranty is invalid. To help you with your product, we invite you to contact us by phone or via our website:

- **+33 (0)9.70.75.30.30**
- **<https://services.swap-europe.com/contact>**

You must create a "ticket" via the web platform.

- Register or create your account.
- Indicate the reference of the tool.
- Choose the subject of your request.
- Describe your problem.
- Attach these files: invoice or sales receipt, photo of the identification plate (serial number), photo of the part you need (for example: pins on the transformer plug which are broken).



11. PRODUCT FAILURE

WHAT TO DO IF MY MACHINE BREAKS DOWN?

If you bought your product in a store:

- a) Empty the fuel tank if your product has one.
- b) Make sure that your machine is complete with all accessories supplied, and clean! If this is not the case, the repairer will refuse the machine.

Go to the store with the complete machine and with the receipt or invoice.

If you bought your product on a website:

- a) Empty the fuel tank if your product has one..
- b) Make sure that your machine is complete with all accessories supplied, and clean! If this is not the case, the repairer will refuse the machine.
- c) Create a SWAP-Europe service ticket on the site: <https://services.swap-europe.com> When making the request on SWAP-Europe, you must attach the invoice and the photo of the nameplate (serial number).
- d) Contact the repair station to make sure it is available before dropping off the machine.

Go to the repair station with the complete machine packed, accompanied by the purchase invoice and the station support sheet downloadable after the service request is completed on the SWAP-Europe site

For machines with engine failure from manufacturers BRIGGS & STRATTON, HONDA and RATO, please refer to the following instructions.

Repairs will be done by approved engine manufacturers of these manufacturers, see their site:

- <http://www.briggsandstratton.com/eu/fr>
- <http://www.honda-engines-eu.com/fr/service-network-page;jsessionid=5EE8456CF39CD572AA2AEEDFD290CDAE>
- <https://www.rato-europe.com/it/service-network>

Please keep your original packaging to allow for after-sales service returns or pack your machine with a similar cardboard box of the same dimensions.

For any question concerning our after-sales service you can make a request on our website <https://services.swap-europe.com>

Our hotline remains available at +33 (9) 70 75 30 30.



12. WARRANTY EXCLUSIONS

THE WARRANTY DOES NOT COVER:

- Start-up and setting up of the product.
- Damage resulting from normal wear and tear of the product.
- Damage resulting from improper use of the product.
- Damage resulting from assembly or start-up not in accordance with the user manual.
- Breakdowns related to carburetion beyond 90 days and fouling of carburetors.
- Periodic and standard maintenance events.
- Actions of modification and dismantling that directly void the warranty.
- Products whose original authentication marking (brand, serial number) has been degraded, altered or withdrawn.
- Replacement of consumables.
- The use of non-original parts.
- Breakage of parts following impacts or projections.
- Accessories breakdowns.
- Defects and their consequences linked to any external cause.
- Loss of components and loss due to insufficient screwing.
- Cutting components and any damage related to the loosening of parts.
- Overload or overheating.
- Poor power supply quality: faulty voltage, voltage error, etc.
- Damages resulting from the deprivation of enjoyment of the product during the time necessary for repairs and more generally the costs related to the immobilization of the product.
- The costs of a second opinion established by a third party following an estimate by a SWAP-Europe repair station
- The use of a product which would show a defect or a breakage which was not the subject of an immediate report and/or repair with the services of SWAP-Europe.
- Deterioration linked to transport and storage*.
- Launchers beyond 90 days.
- Oil, petrol, grease.
- Damages related to the use of non-compliant fuels or lubricants.

* In accordance with transport legislation, damage related to transport must be declared to carriers within 48 hours maximum after observation by registered letter with acknowledgement of receipt.

This document is a supplement to your notice, a non-exhaustive list.

Attention: all orders must be checked in the presence of the delivery person. In case of refusal by the delivery person, it you must simply refuse the delivery and notify your refusal.

Reminder: the reserves do not exclude the notification by registered letter with acknowledgement within 72 hours.

Information: Thermal devices must be wintered each season (service available on the SWAP-Europe site). Batteries must be charged before being stored.

HYUNDAI
POWER PRODUCTS

For Inquiries, please contact:

BUILDER SAS

32, Rue Aristide Bergès Z1 31270 Cugnaux, France

Tél.: +33(0)5.34.502.502 Fax : +33(0)5.34.502.503

<http://www.hyundaipower-fr.com/>

Fabriqué en République Populaire de Chine(PRC)